

150 x 90 x 40 cm

59.1" x 35.4" x 15.7"

SIMONCLICK 4/400

5 Años Garantía
Years Guarantee
Jahre Garantie
Ans Garantie
Anos de Garantía
SIMONRACK

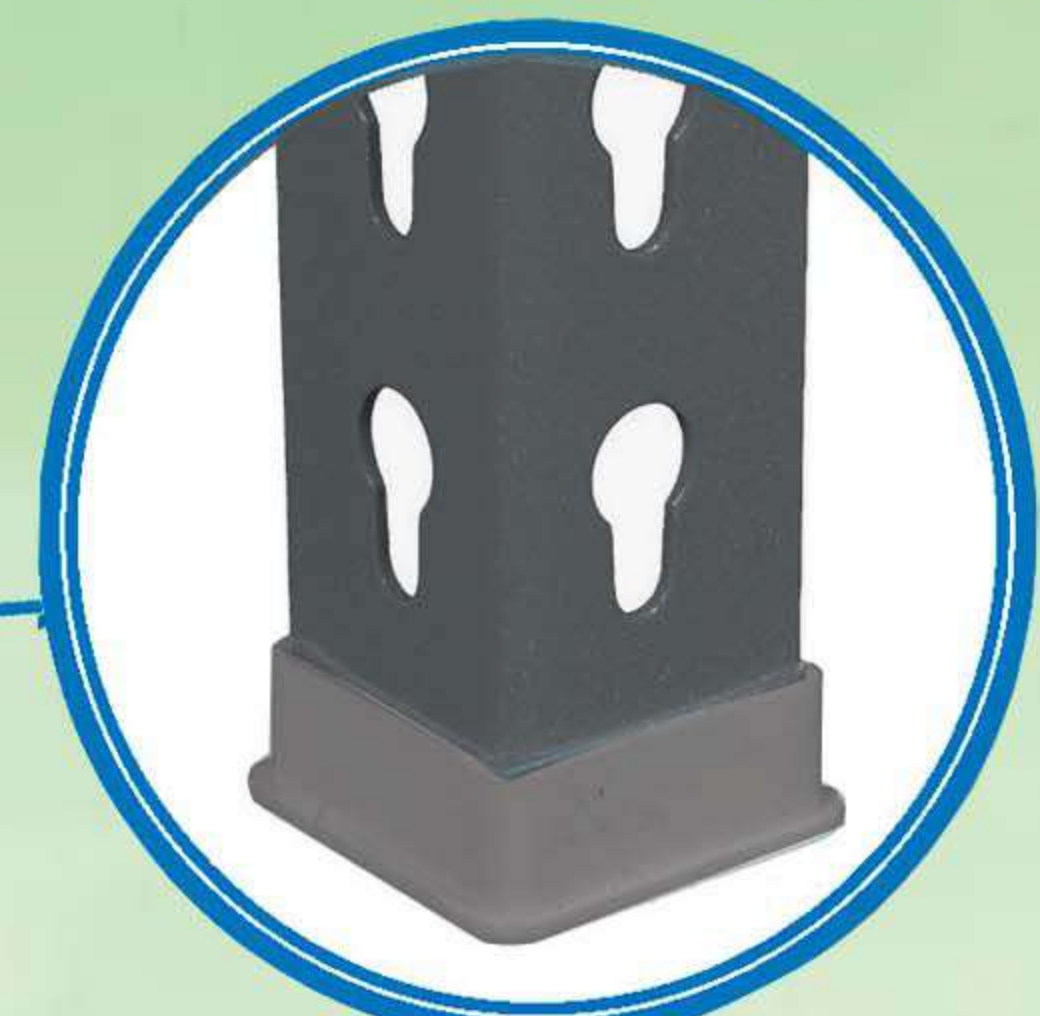
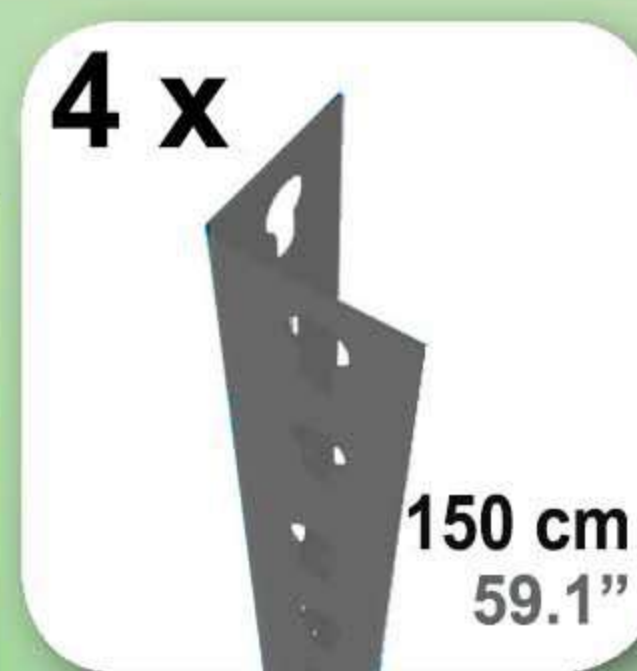

*MEDIDAS EN USO USED MEASUREMENTS
MASSNAHMEN IM EINSATZ MESURES EN EMPLOI MEDIDAS EM USO:
1485 x 910 x 410 mm (58.4" x 35.8" x 16.1")



ESTANTERIAS SIMON S.L. B.50.556.463
PG. ALFAMEN C/ POLIGONO C, N°3
ALFAMEN (ZARAGOZA)

www.simonrack.com



www.simonrack.com



Simon Rack
SINCE 1964 - MANUFACTURER



INSTRUCTIONS

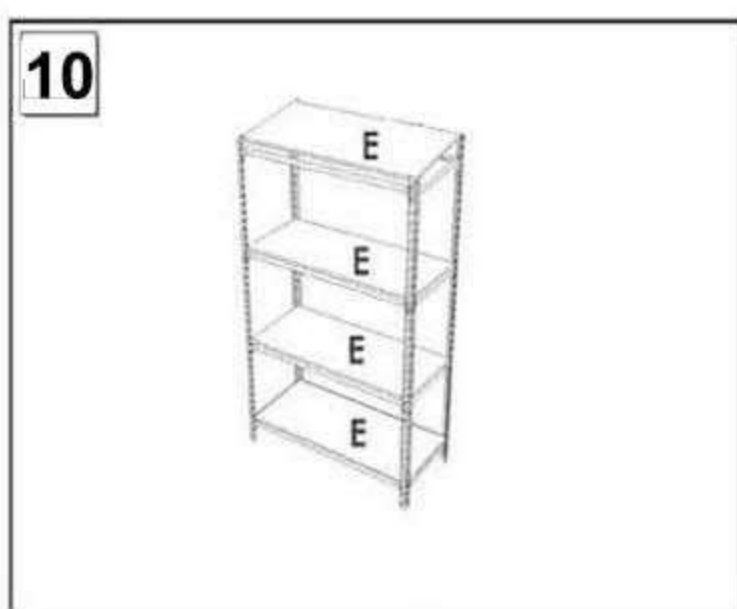
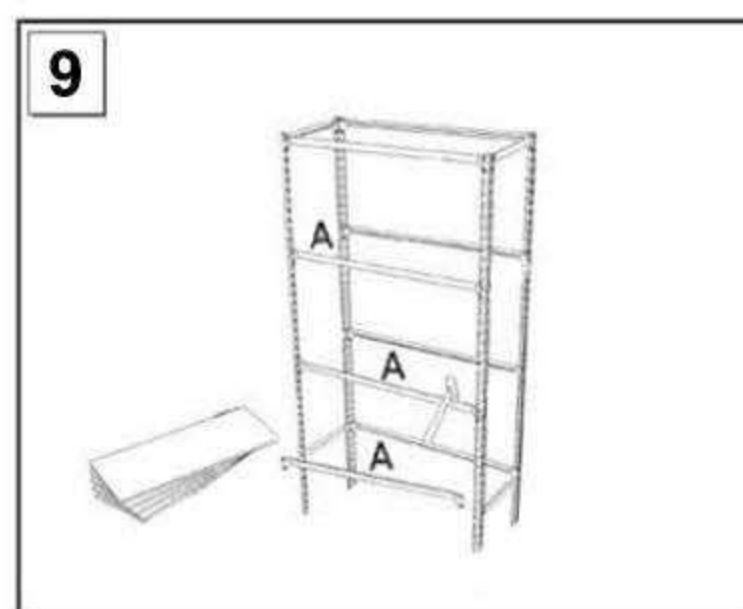
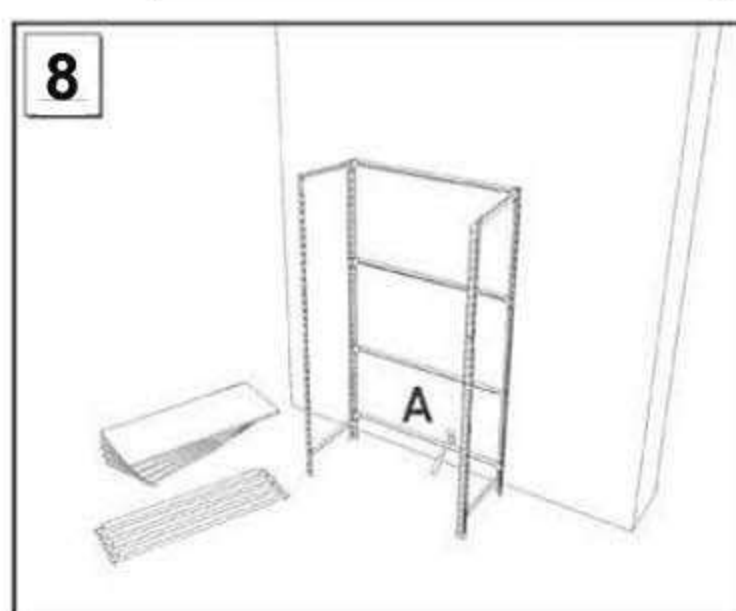
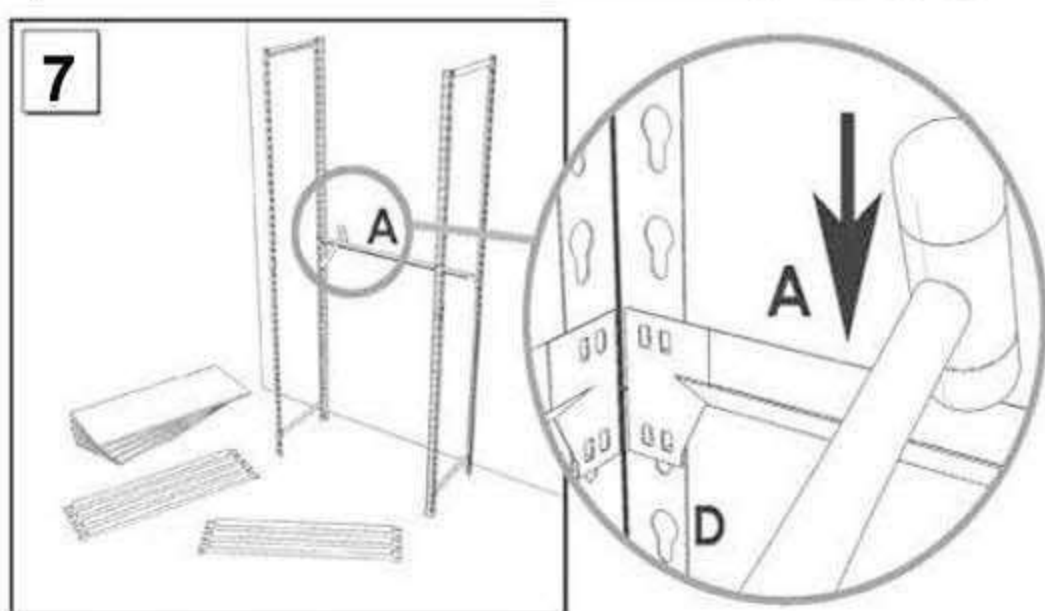
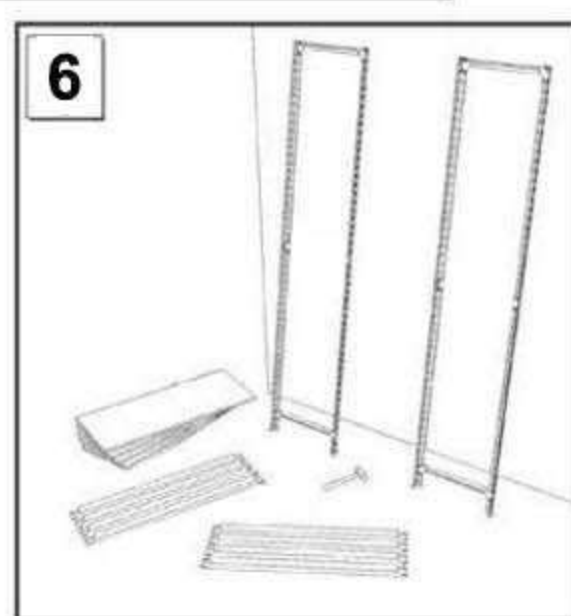
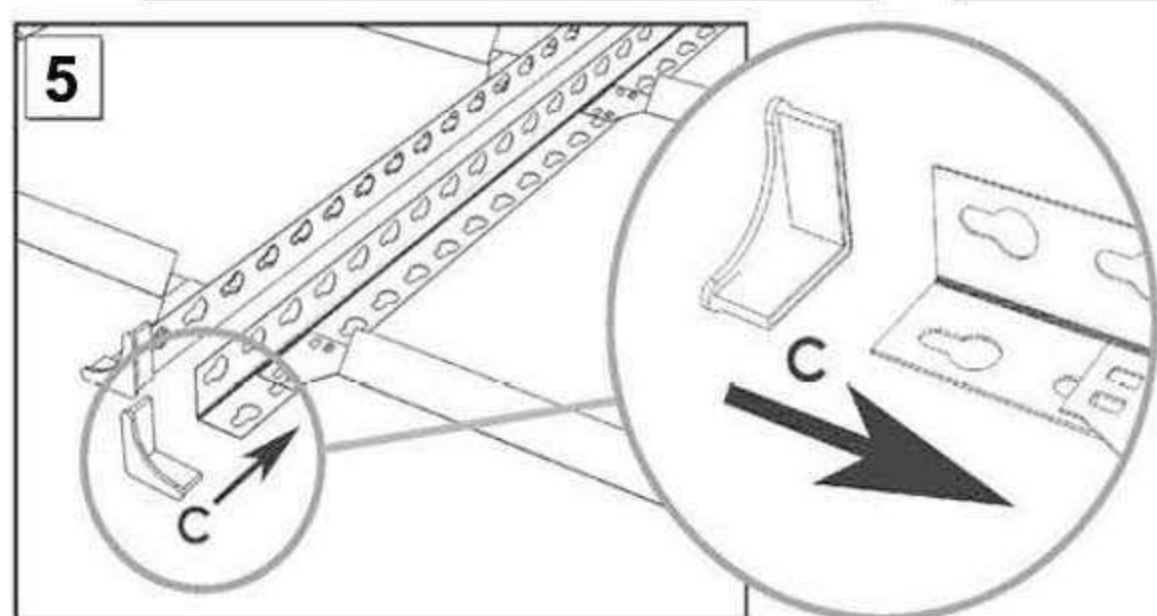
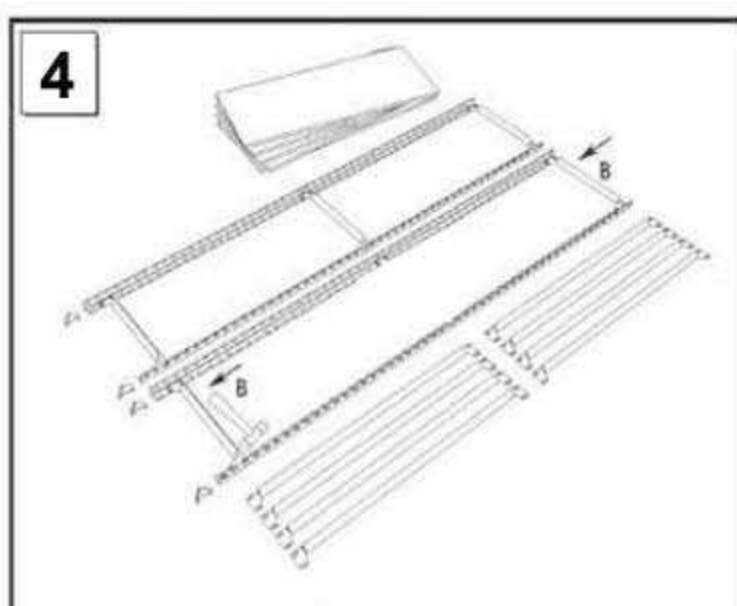
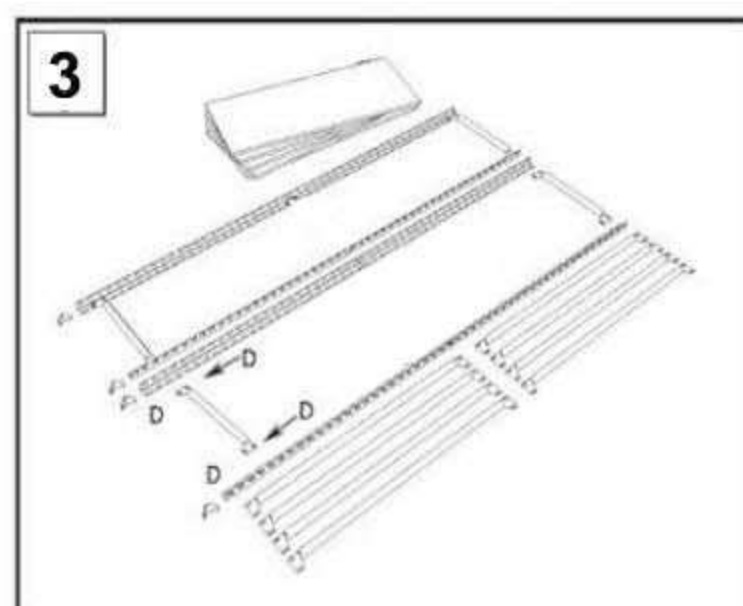
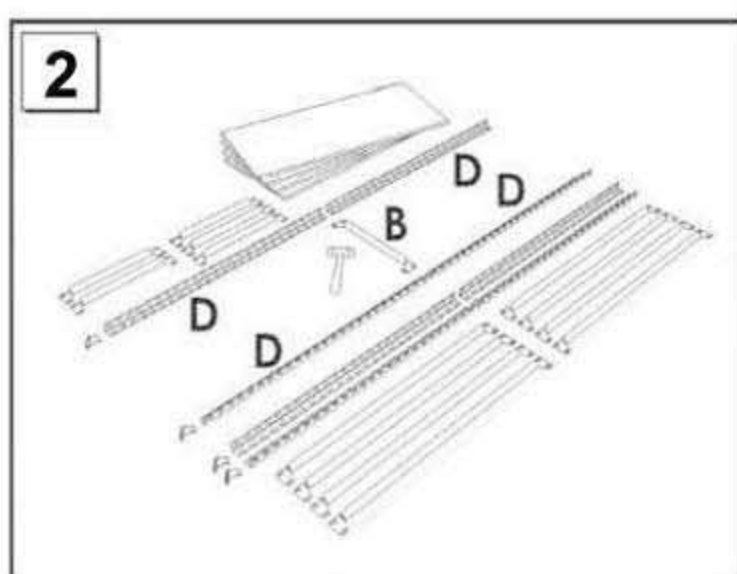
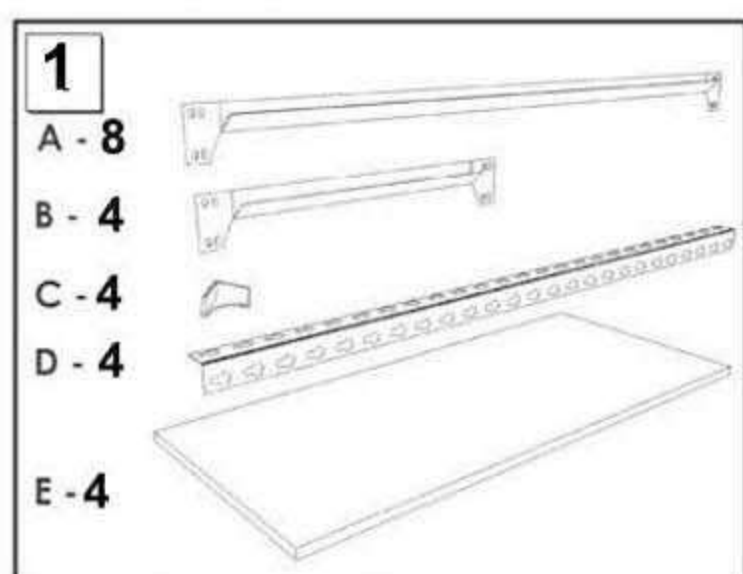

www.simonrack.com • www.instructionsrack.com • maderclick

SIMONCLASSIC



SIMONCLICK



SIMONOFFICE



SIMONTALLER



BANCOS DE TRABAJO WORK BENCHES



SIMONHOME



TAQUILLAS LOCKER



SIMONTITÁN



SIMONINOX



SIMONPALET



SIMONLEVER

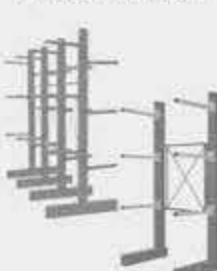

ALTILLOS Y PASILLOS ELEVADOS PLATFORMS AND MEZZANINES

